

MONTAGEANLEITUNG
INSTALLATION INSTRUCTIONS

WASH POINT

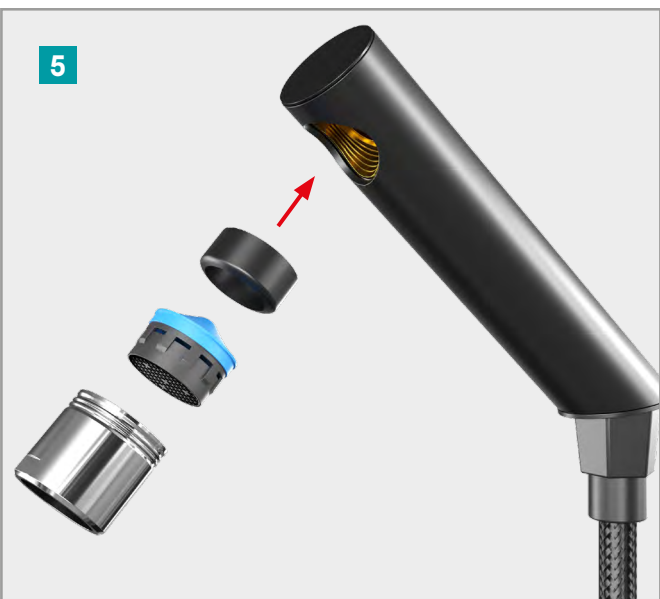

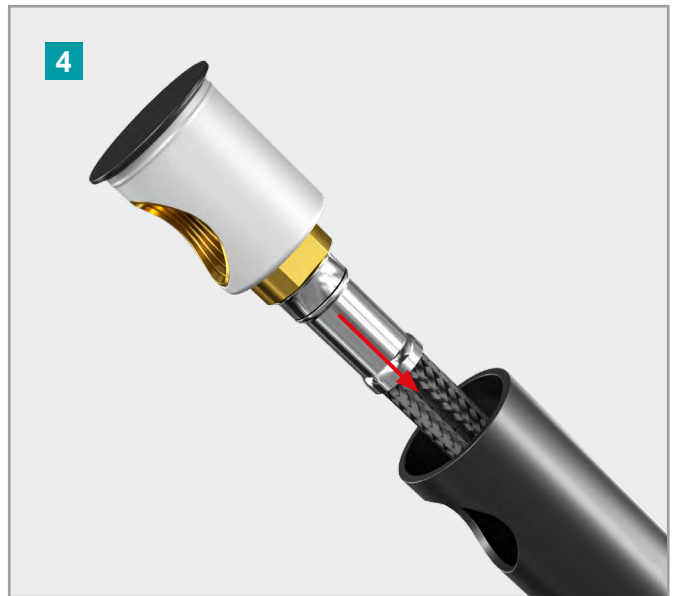
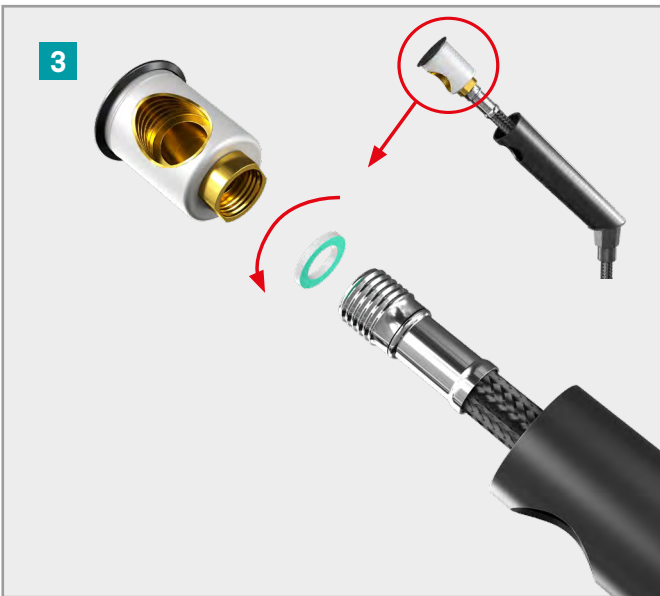

6

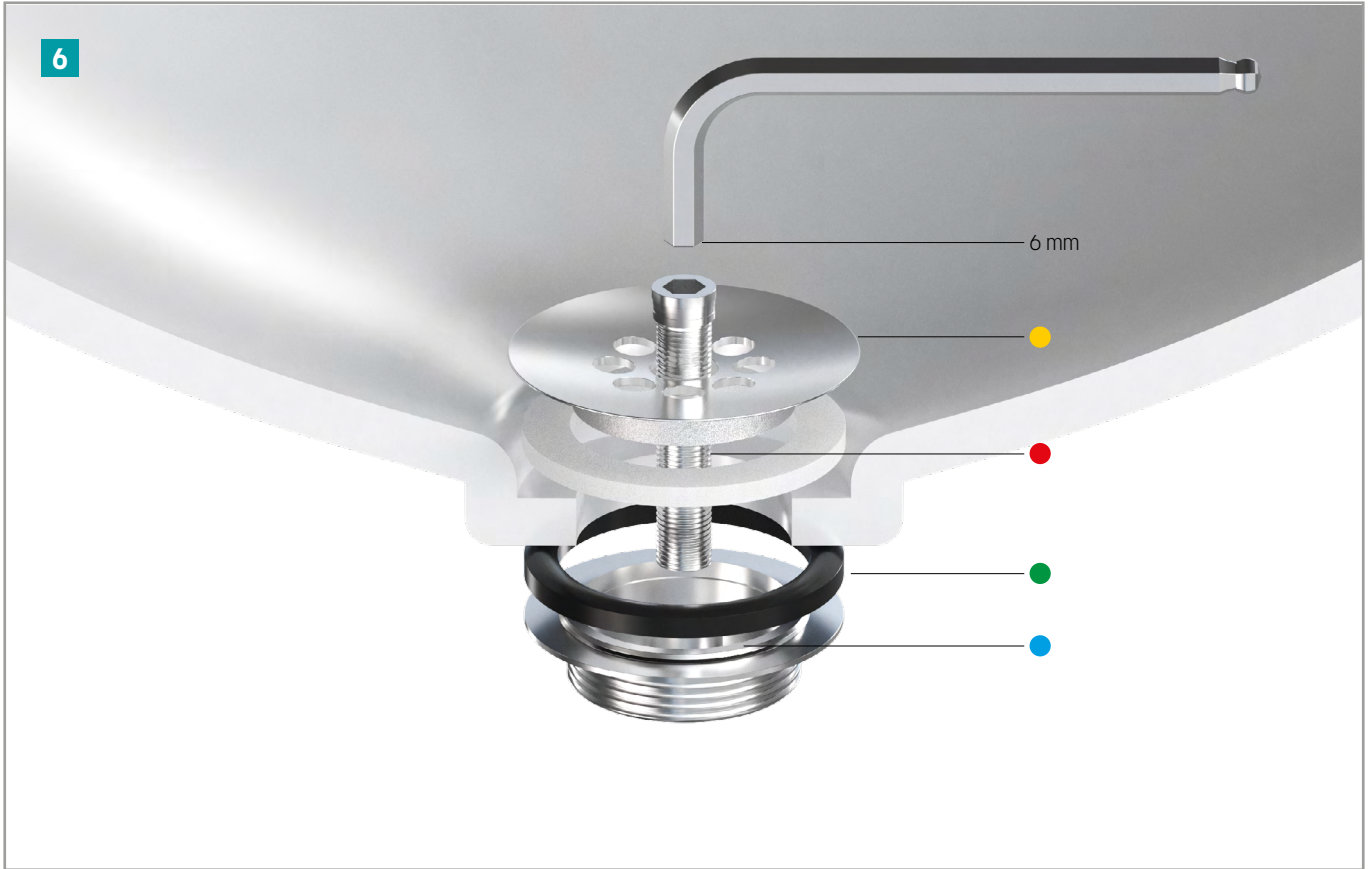

- Siebenteil
- Schraube
- Dichtungsring
- R 5/4" Ventilunterteil

- Pre-screen
- Screw
- Sealing ring
- 5/4" valve body

7

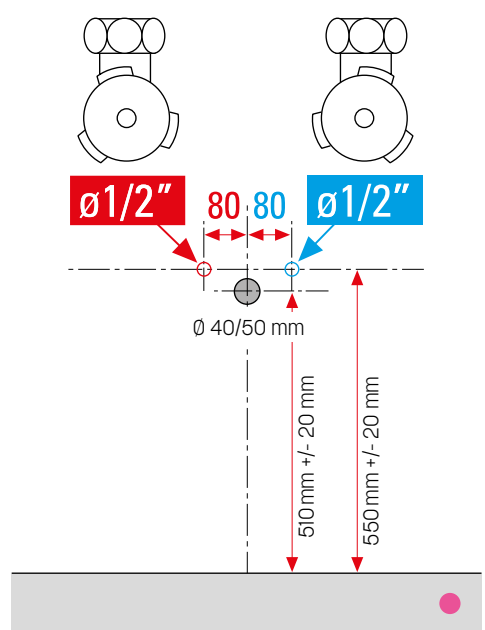

8

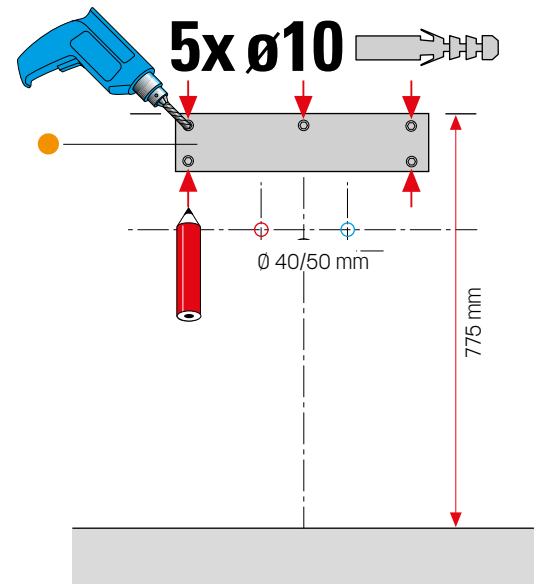
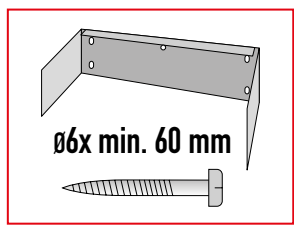

9

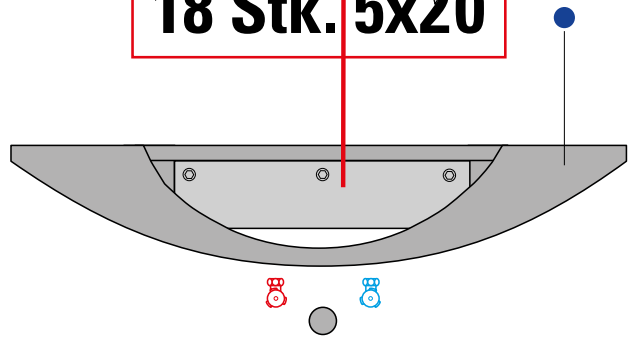
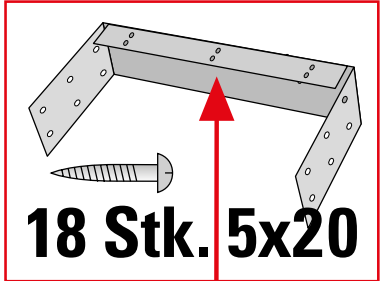

- Fußboden
- Waschbeckenhalter
- Ablage
- Floor
- Washbasin mount
- Shelf

10

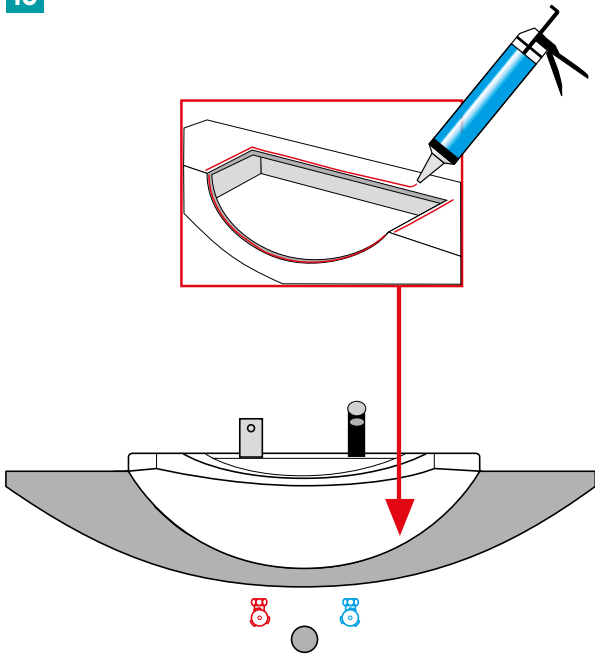

11

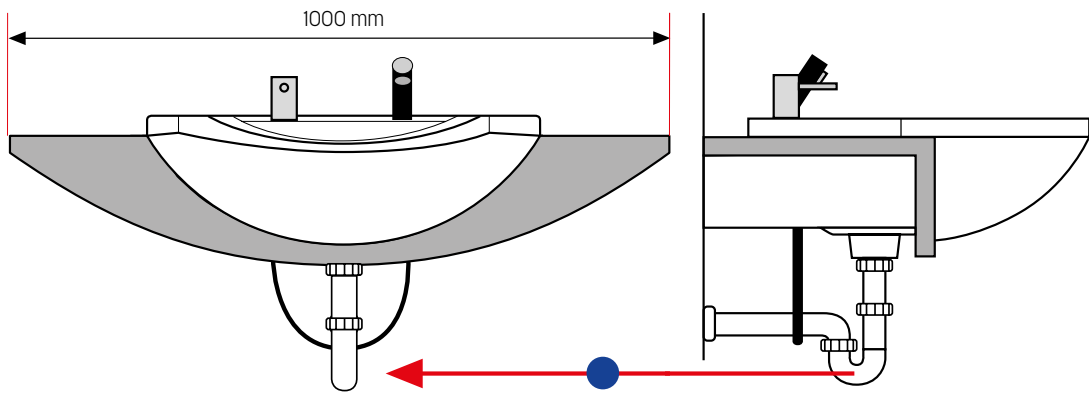
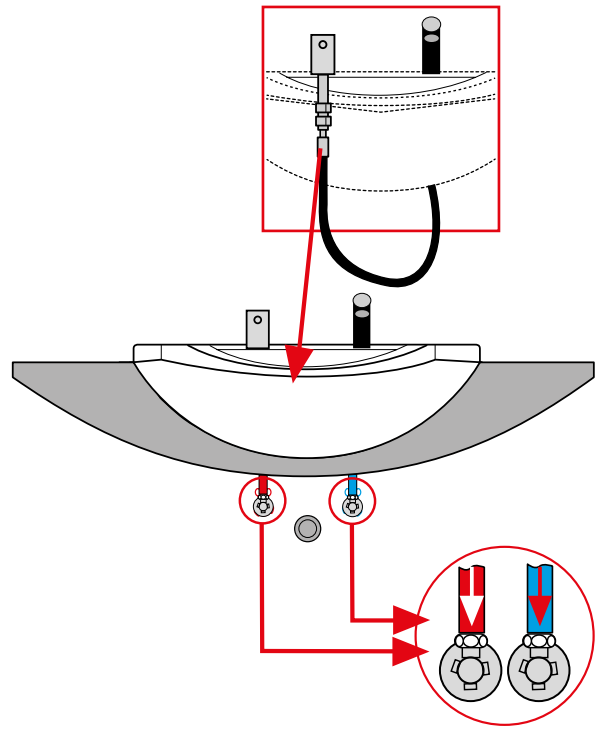

● Sifon

● Siphon

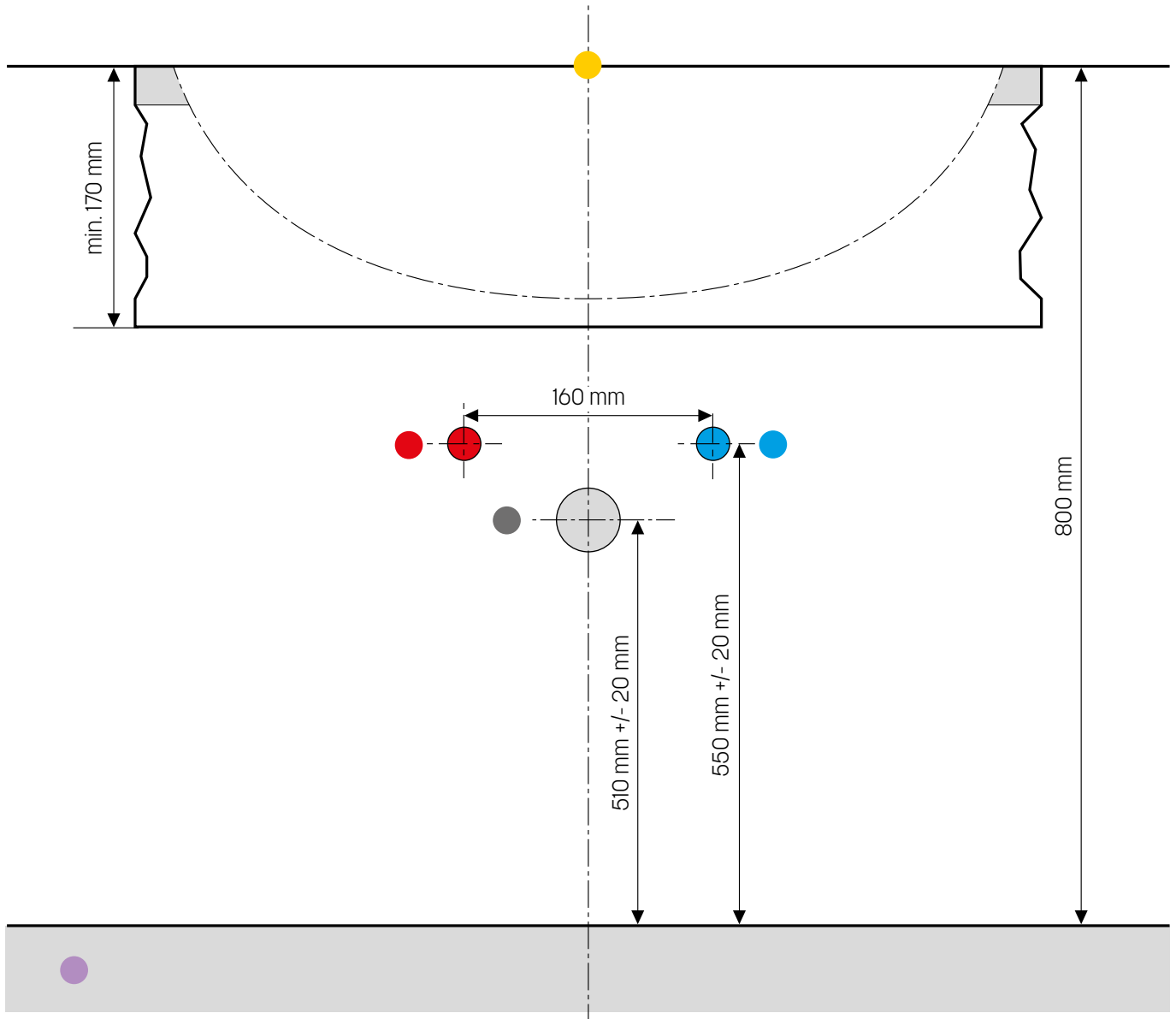

- Oberkante Ablage
- Wasseranschluss R 1/2" innen/warm
- Wasseranschluss R 1/2" innen/kalt
- Siphonanschluss \varnothing 32/40 mm oder \varnothing 32/50 mm
- Fußboden



- Top edge of board
- Water connection internally R 1/2" / warm
- Water connection internally R 1/2" / cold
- Siphon connector \varnothing 32/40 mm or \varnothing 32/50 mm
- Floor



Follow Jobst

Jobst GmbH
Albert-Einstein-Str. 4
D-73529 Schwäbisch Gmünd

[#welovehairstylists](#)

 +49 7171 82004
 mail@jobst-salon.de
 www.jobst-salon.de

